

REVISIONS

P	LTR	DESCRIPTION	DATE	DWN	APVD
	C	REDRAWN IN CREO	06JAN2020	VF	EFG

LINE TERMINATION M12 NICKEL PLATED BRASS FITTED WITH 2-NICKEL PLATED BRASS LOCKNUTS

MOULDED RESIN INSULATOR

HERMETICALLY SEALED GLASS DISPLAY PANEL

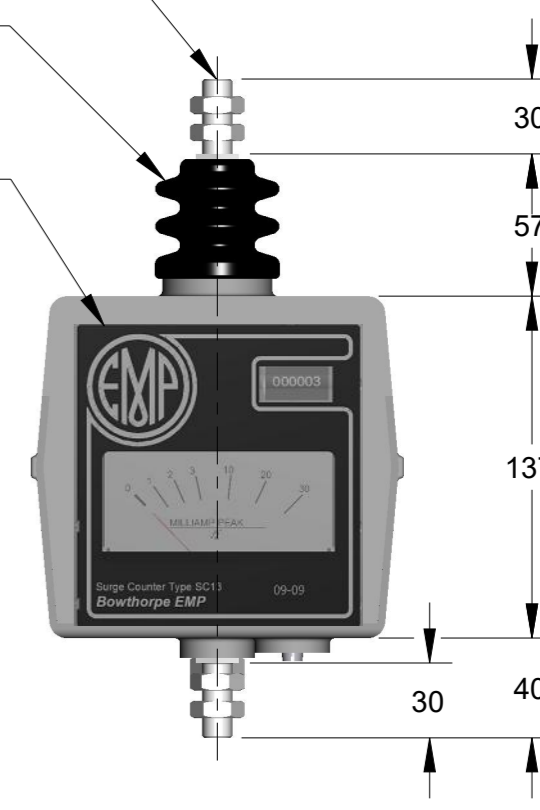
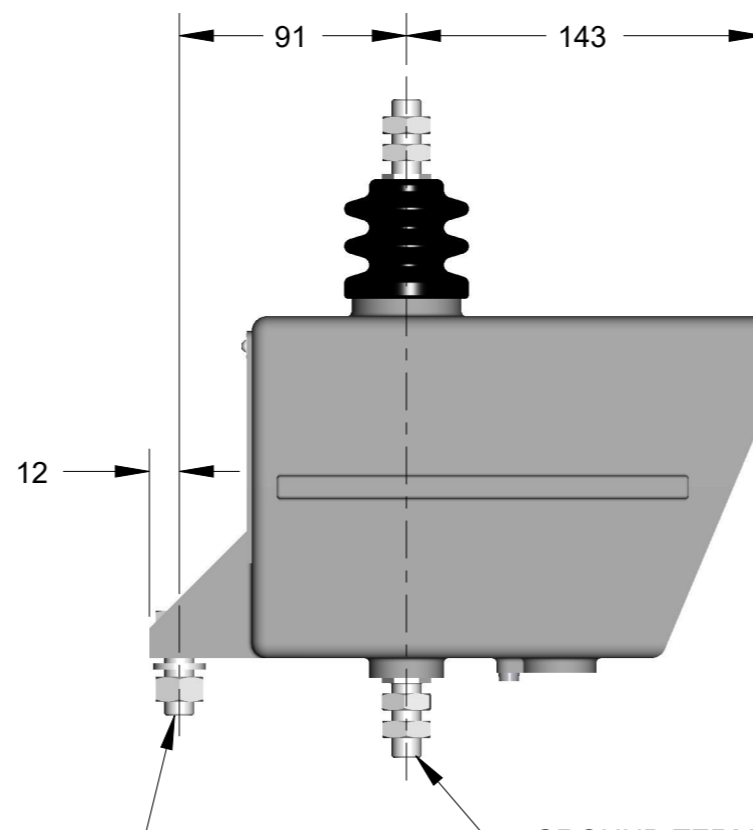
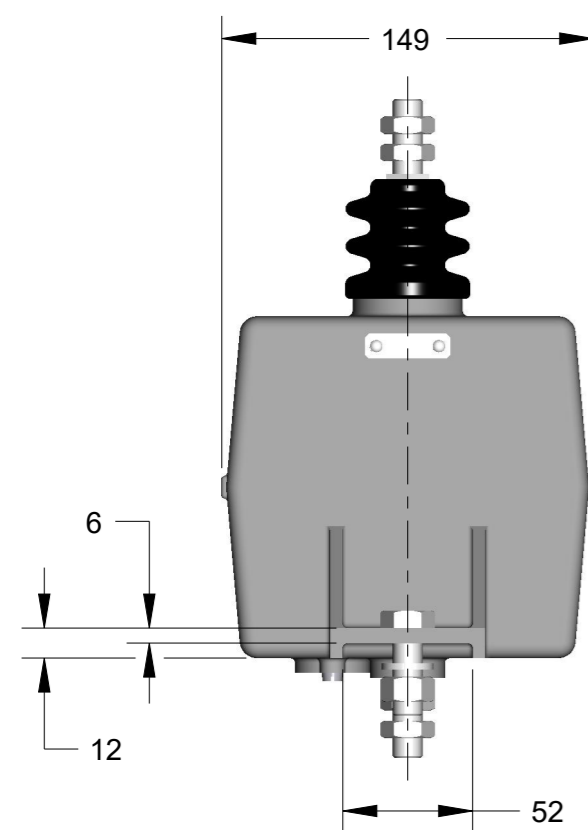

M12x35 STAINLESS STEEL STEEL SET SCREW WITH FULLNUT AND SPRING WASHER

GROUND TERMINATION M12 NICKEL PLATED BRASS FITTED WITH 2-NICKEL PLATED BRASS LOCKNUTS

MAX TIGHTENING TORQUE FOR CONNECTIONS AND MOUNTINGS 40 Nm

COUNTER CASE OF DIE CAST SILICON ALUMINIUM EPOXY POWDER COATED

METER SCALE SHOWN IS TYPICAL ONLY

PROTECTION CLASSIFICATION IP 67

WEIGHT 2.7 kg APPROX.

ALL DIMENSIONS NOMINAL UNLESS SPECIFIED

CJ2983-000

PART NO.

THIS DRAWING IS A CONTROLLED DOCUMENT.		DWN 06JAN2020 V.FUZETTI				
		CHK 06JAN2020 E.F.GASTALDI				
		APVD 06JAN2020 S.A.KUMAR	NAME SURGE COUNTER TYPE: SC13			
DIMENSIONS: mm		PRODUCT SPEC	SIZE	CAGE CODE	DRAWING NO	RESTRICTED TO
TOLERANCES UNLESS OTHERWISE SPECIFIED:		APPLICATION SPEC	A3	00779	C-LA-17002	-
0 PLC ±-		WEIGHT	NOTE		SCALE	SHEET
1 PLC ±-		CUSTOMER DRAWING		NTS	1 OF 1	REV
2 PLC ±-						C
3 PLC ±-						
4 PLC ±-						
ANGLES ±-						
MATERIAL						
FINISH						
-						
-						